





产品图片	Features 产品特性	Application 应用
 DIP8  SMD8	<ul style="list-style-type: none"> ●Contact Form 触点形式 2a ●Load Voltage 输出电压 100V ●Load Current 输出电流 0.5A ●Low Off-State Leakage Current 漏电流 1μA 	<ul style="list-style-type: none"> ●Automatic Test Equipment 自动检测设备 ●Telephone Equipment 通信设备 ●Sensing Equipment 传感设备 ●Security Equipment 安全设备 ●I/O Modules I/O 模块 ●Modem 调制解调器

Type 种类

Output rating 输出额定		Marking model 标 刻型号	Part No. 订货型号	
Load voltage 负载电压	Load current 负载电流		DIP 双列直插	SMD 表面贴装
100V	0.5A	BCW215	BCW215	BCW215A

注：表示引脚类型的“A”未标刻在产品上，订货依据订货示例型号。

Dimensions 外形尺寸

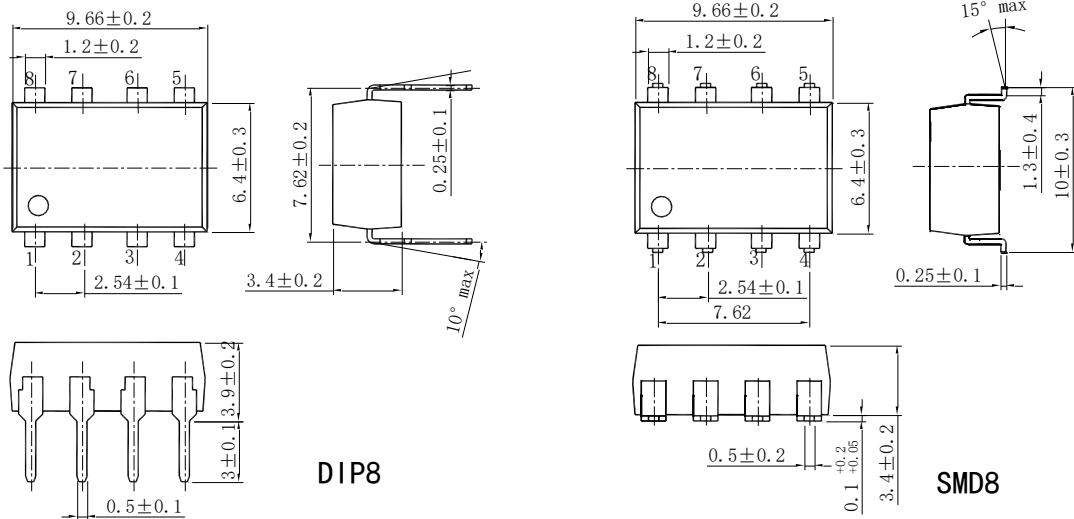

Terminal Identification 引脚标识 Wiring Diagram 接线图

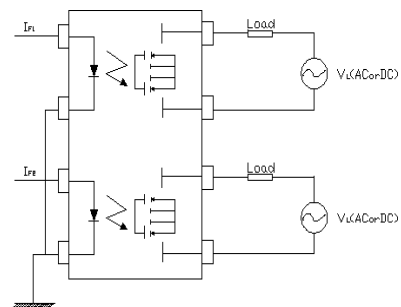
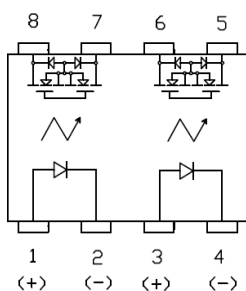

通讯地址：陕西省西安市国家民用航天产业基地航天中路385号众创广场11层1101.1102.1104室

生产地址：陕西省宝鸡市陈仓区群力路1号邮政编码：721300

电话：(0917)-6293969 18609177833

传 真：(0917)-6293969



Technical parameters 技术参数 (Ambient Temperature 25°C)

I/O Absolute Maximum Ratings 输入输出电气参数最大值

Item 项目		Symbol 符号	BCW215	
Operating Temperature 工作温度		T_{OPR}	-40°C~+85°C	
Storage Temperature 储存温度		T_{STG}	-40°C~+100°C	
Input 输入	Continuous LED Current 工作电流	MAX. 最大值	I_F	50mA
	Peak LED Current LED 峰值电流 (f=100Hz, Duty=1%)	MAX. 最大值	I_{FP}	1A
	LED Reverse Voltage 反向电压	MAX. 最大值	V_R	5V
	Input Power Dissipation 输入功耗	MAX. 最大值	P_{IN}	75mW
Output 输出	Load Voltage 输出电压	MAX. 最大值	V_L	100V (AC peak or DC)
	Load Current 输出电流	MAX. 最大值	I_L	0.5A
	Peak Load Current 峰值输出电流 (100ms, 1shot)	MAX. 最大值	I_{PEAK}	0.9A
	Output Power Dissipation 输出功耗	MAX. 最大值	P_{OUT}	800mW
Total Power Dissipation 总功耗		MAX. 最大值	P_T	850mW
I/O Breakdown Voltage 输入输出间隔离电压		MAX. 最大值	$V_{I/O}$	3750Vrms

Electrical Specifications 输入输出电气参数

Item 项目		Symbol 符号	BCW214	Conditions 条件	
Input 输入	LED Forward Voltage 正向电压	TYP. 典型值	1.25V	$I_F=10mA$	
		MAX. 最大值	1.5V		
	Operation LED Current 接通电流	TYP. 典型值	$I_{F ON}$	0.9mA	
MAX. 最大值			3mA		
	Recovery LED Voltage 关断电压	MIN. 最小值	$V_{F OFF}$	0.5V	
Output 输出	On-Resistance 导通电阻	TYP. 典型值	R_{ON}	$I_F=5mA, I_L=Rating,$ within 1sec.	
		MAX. 最大值			4Ω
	Off-State Leakage Current 漏电流	MAX. 最大值	I_{LEAK}	1μA	$V_L=Rating$
	Output Capacitance 输出端容量	TYP. 典型值	C_{OUT}	115pF	$V_L=0V, f=1MHz$
Timeparameters 时间参数	Turn-On Time 接通时间	TYP. 典型值	T_{ON}	0.6ms	$I_F=5mA, I_L=500mA$
		MAX. 最大值		2ms	
	Turn-Off Time 关断时间	TYP. 典型值	T_{OFF}	0.06ms	
		MAX. 最大值		0.2ms	
I/O 输入输出	I/O Insulation Resistance 绝缘电阻	MIN. 最小值	$R_{I/O}$	1000MΩ	
	I/O Capacitance 隔离电容	TYP. 典型值	$C_{I/O}$	1.5pF	f=1MHz



PhotoMOS 光 MOS 继电器 (SMD8/DIP8)

Reference Data 参考数值 (BCW215)

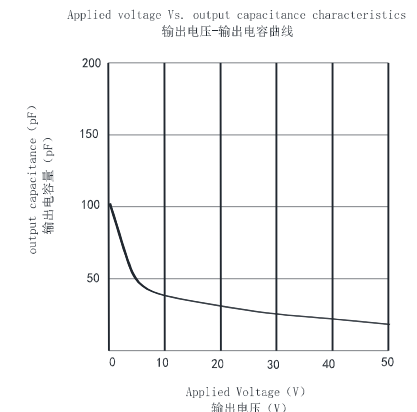
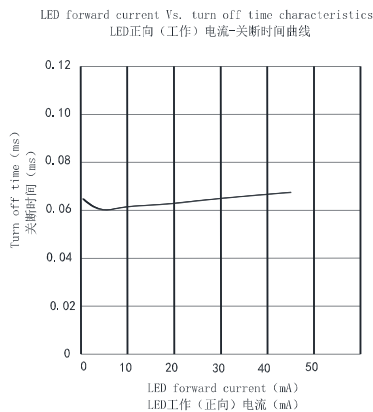
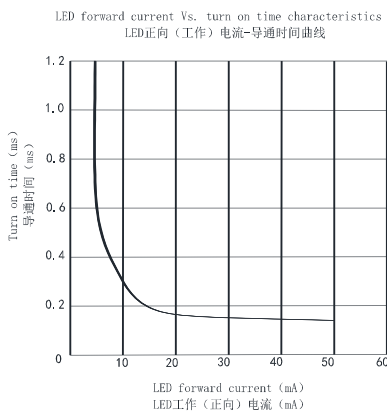
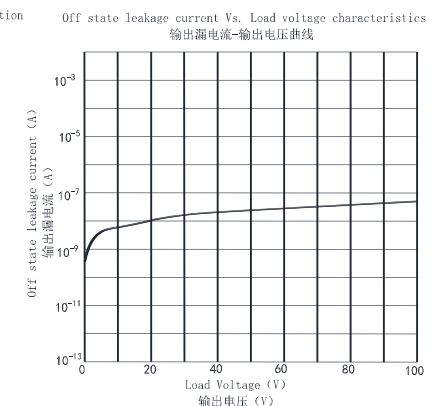
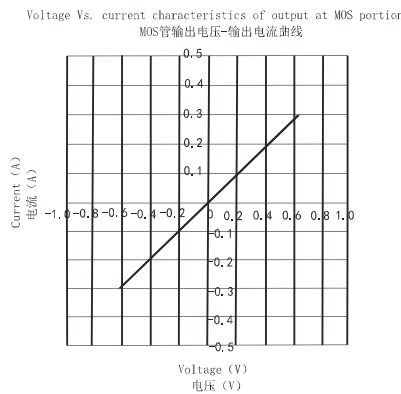
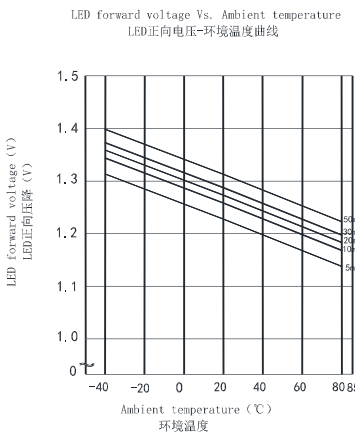
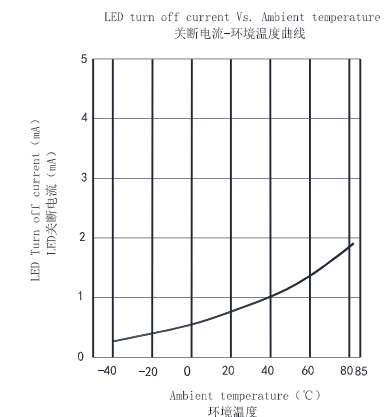
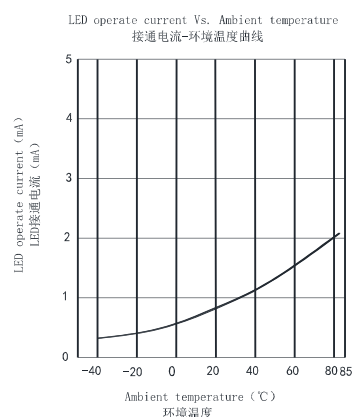
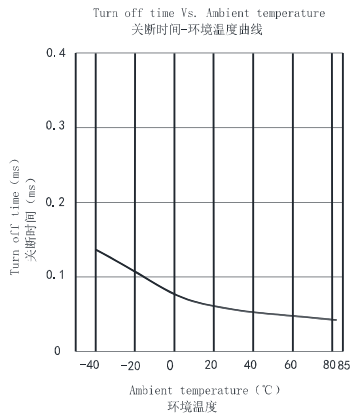
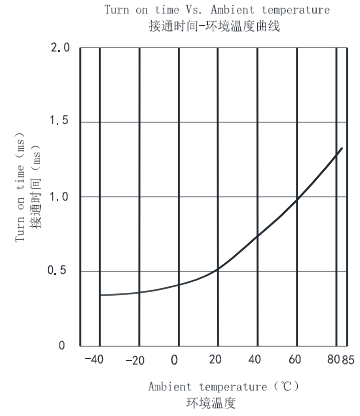
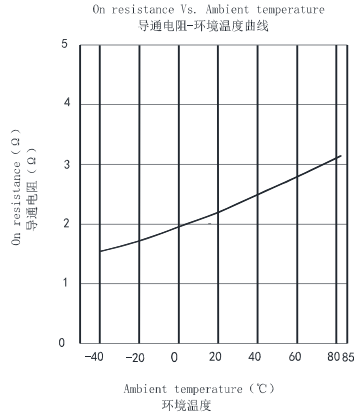
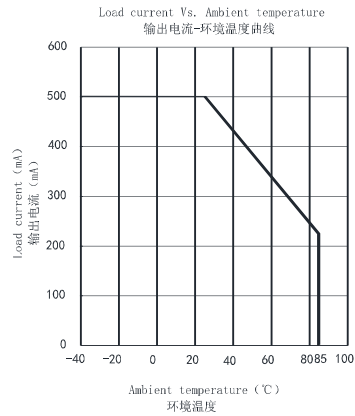

通讯地址: 陕西省西安市国家民用航天产业基地航天中路385号众创广场11层1101.1102.1104室

生产地址: 陕西省宝鸡市陈仓区群力路1号 邮政编码: 721300

电话: (0917)-6293969 18609177833

传 真: (0917)-6293969